

**DEA**<sup>®</sup>



SLIDING



**LIVI**

Automation for sliding gates

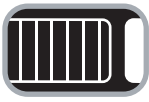

# Electromechanical operator for sliding gates

## LIVI

THE STURDINESS, BORN OF THE LONG EXPERIENCE

LIVI is the operator for sliding gates from 350 kg to 900 kg , which combines a great **sturdiness** and **reliability** with an agreeable and original design, which has been marking out this product for several years.

Thanks to the mechanical or electronic clutch, the **safety** is assured.

The control board is integrated in the case, making so still easier the already quick installation of Livi 400 and its programming is rapid, precise and stable.



RANGE **LIVI**

### Range RR\*

**6RR:** operator 230V ac, for gates up to 600 kg, built-in control board art. 203RR\*.

**9RR:** operator 230V ac, for gates up to 900 kg, built-in control board art. 203RR\*.

**805RR:** operator 230V ac, for gates up to 800 kg, built-in control board art. 203RR\*, not self-locking.

**3/24RR:** operator 24V dc, for gates up to 350 kg, built-in control board art. 124RR\*.

**3/24RRB:** operator 24V dc, for gates up to 350 kg, built-in control board art. 124RR\*, 2 integrated batteries 12V 1,2Ah.

**6/24RR:** operator 24V dc, for gates up to 600 kg, built-in control board art. 124RR\*.

**6/24RRB:** operator 24V dc, for gates up to 600 kg, built-in control board art. 124RR\*, 2 integrated batteries 12V 1,2Ah.

**Models 3/24RR and 6/24RR are also available with built-in limit switches.**

*\*all control boards included in the RR range come equipped with a 2-channel wireless receiver 433 Mhz, pedestrian opening, electronic adjustment of speed and force, reverser function on obstacle and slow-down.*

*All functions are adjusted by 3 buttons and a digital display.*

### Other 230V models:

**400:** operator 230V ac, for gates up to 400 kg, with mechanical clutch.

**401:** operator 230V ac, for gates up to 400 kg, with mechanical clutch and built-in control board art. 201.

**403E:** operator 230V ac, for gates up to 400 Kg., built-in control board art. 212E

**800:** operator 230V ac, for gates up to 800 kg, with mechanical clutch.

**801:** operator 230V ac, for gates up to 800 kg, with mechanical clutch and built-in control board art. 201

**803E:** operator 230V ac, for gates up to 800 Kg., built-in control board art. 212E

**804:** operator 230V ac, for gates up to 800 kg, with mechanical clutch, not self-locking.

*DEA System control boards are planned to optimize the performances of Livi 400 range. It is suggested to use articles with control boards integrated.*

### The models

- Product in conformity with European standards.
- Electromechanical automation, 230V ac and 24V dc
- Suitable for gates from 350 kg to 900 kg.
- Easy to install, thanks to the adjustable fixing plate.
- Integrated limit switches (on 230V ac versions).
- Simple unlocking system by key.
- Mechanical and electronic clutch (on RR models).
- Grease soaked gear motor.
- Silent.



*Simple unlocking system by key.*



*Metal body and highly sturdy components.*



*All control boards included in the RR range can be easily programmed through display and 3 buttons.*

## accessories

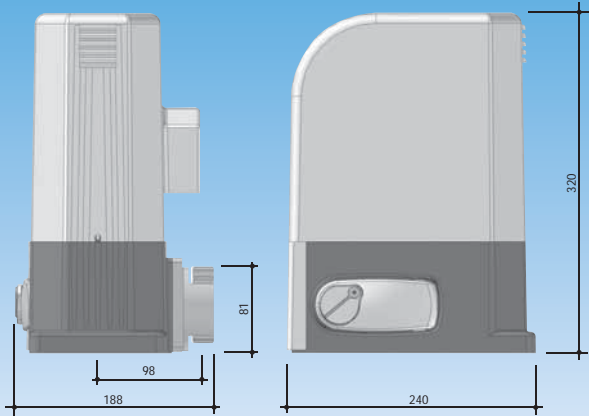

**Art. 111**  
NYLON rack.



**Art. 112**  
22x22 GALVANIZED rack.



**Art. 113**  
30x12 GALVANIZED rack  
with zinc-plated spacers.



**Art. 460**  
Foundation plate to be  
placed in the concrete.

## Technical information

Model	400 - 401 6RR - 403E	800 - 801 9RR - 803E	804 805RR	3/24RR 3/24/RRB 3/24RR/F 3/24RRB/F	6/24RR 6/24/RRB 6/24RR/F 6/24RRB/F
Motor power supply (V)	230 V a.c.	230 V a.c.	230 V a.c.	24 V d.c.	24 V d.c.
Capacity (W)	320	450	350	80	80
Duty cycle	30%	30%	30%	80%	80%
Max thrust (N)	340	490	275	210	260
Operating temperature (°C)	-20°÷40°	-20°÷40°	-20°÷40°	-20°÷40°	-20°÷40°
Speed (m/min)	10	10	10,8	10	8,2
Protection level	IPX4	IPX4	IPX4	IPX4	IPX4
Weight with packing (Kg)	11	12,5	12,5	12	12



**The products**

Electromechanical barriers		Sliding gates		Sectional and garage doors			
PASS	STOP	LIVI 400	GULLIVER	LIVI 902	SPAZIO	LIVI 800 C	LATO
Swing gates						Roller shutter	
LIVI 500	ANGOLO	GHOST 200	OLI 600	WING 302	LOOK	WILL	

**The accessories**



**Digikey:**  
Safe and reliable,  
available wireless  
and hard-wired.



**Radio devices:**  
frequency 433,92 Mhz,  
available Dip-Switch  
or Self-Learning type.



**Flashing light**  
with built-in  
433,92 Mhz  
aerial.



**Control boards:**  
230V a.c. e 24V d.c.,  
exact and simple  
programming.



**Safety beams:**  
reliable and easy  
to install.



**Programming keyboard for**  
transponder and wireless  
transmission systems; it allows  
you to personalize installations  
with fitter/installation codes.



**DEA SYSTEM S.p.A.**  
GATE AUTOMATION  
Via della Tecnica, 6 - 36013 PIOVENE ROCCHETTE (VI)  
Telefono: + 39 0445 550789 - Telefax: + 39 0445 550265  
www.deasystem.com  
deasystem@deasystem.com

DEALER STAMP